



CERTIFICATE OF APPROVAL

No CF192

This is to certify that, in accordance with
TS00 General Requirements for Certification of Fire Protection Products
The undermentioned products of

JELD-WEN UK LIMITED

Woodhouse Mill, Sheffield, South Yorkshire S13 9WH

Tel: 0114 2542000 Fax: 0114 2696696

Have been assessed against the requirements of the Technical Schedule(s)
denoted below and are approved for use subject to the conditions
appended hereto:

CERTIFIED PRODUCT

JELD-WEN UK Limited FD30
Timber Door Assemblies
(Tubeboard Construction)

TECHNICAL SCHEDULE

TS10 Fire Resisting Door
Assemblies with Non-Metallic
Leaves

Signed and sealed for and on behalf of Warringtonfire Testing and Certification Limited

Paul Duggan
Certification Manager



Issued: 22nd March 2022
Revised: 6th June 2022
Valid to: 15th March 2025





CERTIFICATE No CF192

JELD-WEN UK LIMITED

JELD-WEN UK LTD. FD30 TIMBER DOOR ASSEMBLIES (TUBEBOARD CONSTRUCTION)

This approval relates to the use of the above doors in providing fire resistance of 30 minutes insulation (if incorporating not more than 20% of uninsulating glass) and 30 minutes integrity as defined in BS 476: Part 22. Subject to the undermentioned conditions, the doors would be expected to meet the relevant requirements of BS 9999 for FD30 door assemblies when used in accordance with the provisions therein.

1. This certification is provided to the client for its own purposes, and we cannot opine on whether it will be accepted by Building Control authorities or any other third parties for any purpose.
2. The doors are approved on the basis of:
 - i) Initial type testing
 - ii) A design appraisal against TS10
 - iii) Inspection and surveillance of factory production control
 - iv) Certification under a CERTIFIRE approved Quality Management System
 - v) Audit testing in accordance with TS10
3. The doors comprise timber cored leaves in various finishes for use with timber frames, with intumescent edge seals (ITT FD30).
4. This approval is applicable to both complete door assemblies and door leaves. Where the door is not supplied in a fully fitted form it is a condition of this approval that an agreed Data Sheet accompanies the product and is complied with in its entirety. Failure to do so will invalidate this approval and may jeopardise the fire performance of the door.
5. This approval is applicable to latched and unlatched, single-acting, single and double-leaf, ITT assemblies with or without overpanels, at leaf dimensions up to those given in Table 1 below:
6. Glazing shall only be undertaken by the door manufacturer, or a CERTIFIRE approved Licensed Door Processor, and shall be in accordance with the Data Information Sheet and Construction Specification. No site cutting or glazing of apertures is permitted.
7. Hardware items, including closing devices and intumescent fire seals, shall be as specified in the Data Sheet.

Page 2 of 4 Signed
E/128, E/262, E/365

Issued: 22nd March 2022
Revised: 6th June 2022
Valid to: 15th March 2025



CERTIFICATE No CF192 JELD-WEN UK LIMITED

JELD-WEN UK LTD. FD30 TIMBER DOOR ASSEMBLIES (TUBEBOARD CONSTRUCTION)

- The door assembly shall be mechanically fixed to wall constructions having a fire resistance of at least 30 minutes.
- Labels to the CERTIFIRE design, or approved by CERTIFIRE, referencing CERTIFIRE and CERTIFIRE Ref. No. CF192 and FD30 classifications resistance shall be affixed to each door in the prescribed position.
- This approval relates to on-going production. The product and/or its immediate packaging is identified with the manufacturer's name, the product name or number, the CERTIFIRE name or name and mark, together with the CERTIFIRE certificate number and application when appropriate.

Table 1

Door assemblies with Lorient Polyproducts (Type 617) or Pyroplex (CF355)
15 mm by 4 mm intumescents

Door assembly configuration	Max. Height (mm)	Max. Width (mm)	Max. Area (m ²)
Single-Acting, Single-Leaf Latched / Unlatched	2160 (at 926 wide)	980 (at 2040 high)	2.00
Single-Acting, Double-Leaf Latched / Unlatched	2160 (at 926 wide)	980 (at 2040 high)	2.00

Table 2

Door assemblies with Lorient Polyproducts Ltd reduced intumescent specification
10 mm by 4 mm – type 617 only

Door assembly configuration	Max. Height (mm)	Max. Width (mm)	Max. Area (m ²)
Single-Acting, Single-Leaf Latched Unlatched	2306 (at 925 wide)	1046 (at 2040 high)	2.13
Single-Acting, Double-Leaf Latched / Unlatched	2248 (at 925 wide)	1019 (at 2040 high)	2.08



CERTIFICATE No CF192

JELD-WEN UK LIMITED

Doorset configurations in Table 1 may incorporate Jeld-Wen UK CF192 overpanels which include a transom rail as detailed within the data sheet.

Under no circumstances must the maximum height, maximum width or maximum area be exceeded without separate CERTIFIRE approval.

Double-leaf door assemblies (including plain / square meeting stiles only) may incorporate leaves of unequal width providing the smaller leaf is a minimum of 40% of the width of the larger leaf.

Page 4 of 4 Signed
E/128, E/262, E/365

Issued: 22nd March 2022
Revised: 6th June 2022
Valid to: 15th March 2025

**JELD-WEN UK LIMITED. FD30 TIMBER DOOR ASSEMBLIES
(TUBEBOARD CONSTRUCTION)
CF192 DATA SHEET**

1. General

This door leaf has been fire tested and is certified by CERTIFIRE as being capable of providing fire resistance of 30 minutes integrity and 30 minutes insulation (if incorporating not more than 20% of uninsulated glass) as defined in BS 476: Part 22, when installed in accordance with the following conditions. Subject to these, the door will meet the relevant requirements of BS 9999 for FD30 when used in accordance with the provisions therein.

In recognition of this, the leaf carries a prefixed label on the top or hanging edge of the door, issued under the terms of the CERTIFIRE scheme. This label uniquely identifies the door leaf, the manufacture of which complies with a CERTIFIRE approved Quality Management System and is subject to on-going surveillance. This label shall not be removed.

It is emphasised that the certification is conditional upon the following instructions being complied with in their entirety. Failure to do so will invalidate this approval and may jeopardise the fire performance of the door. Door assemblies supplied pre-fitted with components by JELD-WEN UK Limited may be considered to meet the requirements in respect of those items.

2. Door Leaf Dimensions

This approval is applicable to single-action, single and double-leaf, latched and unlatched, assemblies at leaf dimensions up to those detailed within Table 1 below.

Table 1

Door assemblies with Lorient Polyproducts (Type 617) or Pyroplex (CF355)
15 mm by 4 mm intumescents

Door assembly configuration	Max. Height (mm)	Max. Width (mm)	Max. Area (m²)
Single-Acting, Single-Leaf Latched / Unlatched	2160 (at 926 wide)	980 (at 2040 high)	2.00
Single-Acting, Double-Leaf Latched / Unlatched	2160 (at 926 wide)	980 (at 2040 high)	2.00

Table 2

Door assemblies with Lorient Polyproducts Ltd **reduced** intumescent specification
10 mm by 4 mm – type 617 only

Door assembly configuration	Max. Height (mm)	Max. Width (mm)	Max. Area (m²)
Single-Acting, Single-Leaf Latched Unlatched	2306 (at 925 wide)	1046 (at 2040 high)	2.13
Single-Acting, Double-Leaf Latched / Unlatched	2248 (at 925 wide)	1019 (at 2040 high)	2.08

Doorset configurations in Table 1 may incorporate Jeld-Wen UK CF192 overpanels which include a transom rail as detailed within the data sheet.

Under no circumstances must the maximum height, maximum width or maximum area be exceeded without separate CERTIFIRE approval.

Double-leaf door assemblies (including plain / square meeting stiles only) may incorporate leaves of unequal width providing the smaller leaf is a minimum of 40% of the width of the larger leaf.

3. Door Frame

To be any of the following:-

Softwood or Hardwood (Solid)	i) Density:	440 kg/m ³ minimum (see note 1)
	ii) Dimensions:	70 mm by 30 mm minimum (see note 2)
	iii) Door Stop:	12 mm deep pinned, screwed, or rebated from solid (440 kg/m ³ min) Where the stop is rebated from solid the overall frame thickness must be increased by 12 mm to accommodate the 12 mm rebate depth.
	Note 1	Softwood / hardwood frames for use with the reduced intumescent specification shall have a min density of 510 kg/m ³ .
	Note 2	Softwood / hardwood frames for use with the reduced intumescent specification require a minimum section size of 74 mm by 30 mm thick.
Softwood (Engineered / laminated)	i) Density:	500 kg/m ³ minimum (see note 3)
	ii) Dimensions:	70 mm by 30 mm minimum (see note 4)
	iii) Door Stop:	12 mm deep pinned, screwed, or rebated from solid (500 kg/m ³ min) Where the stop is rebated from solid the overall frame thickness must be increased by 12 mm to accommodate the 12 mm rebate depth.
	Note 3	Softwood engineered / laminated frames for use with the reduced intumescent specification shall have a min density of 510 kg/m ³ .
	Note 4	Softwood engineered / laminated frames for use with the reduced intumescent specification require a minimum section size of 74 mm by 30 mm thick.
MDF	i) Density:	720 kg/m ³ minimum (see note 5)
	ii) Dimensions:	70 mm by 25 mm minimum (see note 6)
	iii) Door Stop:	12 mm deep pinned, screwed, or rebated from solid (720 kg/m ³ min) Where the stop is rebated from solid the overall frame thickness must be increased by 12 mm to accommodate the 12 mm rebate depth.
	Note 5	MDF frames for use with the reduced intumescent specification shall have a min density of 720 kg/m ³ .
	Note 6	MDF frames for use with the reduced intumescent specification require a minimum section size of 74 mm by 25 mm thick.

Softwood Tri-laminated & Finger Jointed Frames

Softwood tri-laminated & finger jointed frames may be used, subject to compliance with the following specification:

- Single-acting, single-leaf door assemblies only with maximum overall leaf dimensions 2040 mm high by 926 mm wide.
- The door assemblies may be latched or unlatched, in accordance with the specific CERTIFIRE certificate requirements.
- The once rebated knock down frames will be manufactured from clear engineered softwood of minimum density 500 kg/m³ and shall have a minimum overall section of 66 mm wide by 56 mm thick complete with a 13 mm deep rebate.
- Alternatively, the once rebated knock down frames will be manufactured from clear engineered softwood of minimum density 500 kg/m³ and shall have a minimum overall section of 66 mm wide by 52 mm thick complete with a 20 mm deep rebate.
- The softwood frame material will be finger jointed in length only and include a maximum of 3No laminated elements.
- The finger joints will be orientated to the opening face and closing face of the frame only.
- The frame jambs and head will incorporate a 20 mm wide by 4 mm thick CERTIFIRE approved intumescent seal and a Q-Lon Aquamac 21 seal.

Jointing:	Butt joints, mortice and tenon, mitred or half lapped joints with the head screw fixed to the jambs using two steel screws
	MDF frames with Half-lapped joints may be mechanically fixed using 3No 50 mm by 1.6 mm by 1.3 mm staples at 12 mm to 22 mm horizontal centres.
Door to frame gaps:	Not to exceed 4 mm except at threshold where up to 10 mm is permitted and 4 mm at the meeting stiles

Timber 'Split Frames' are permitted providing the section opposite door edge complies with the minimum requirements for single section timber frames.

4. Overpanels / sidepanels

Flush overpanels are not permitted.

Transomed overpanels, manufactured to the same specification as the door leaves, may be included up to 1000 mm high, with a minimum 30 mm thick softwood / hardwood transom rail in accordance with Section 3 of the Data Sheet.

Mullioned sidepanels, manufactured to the same specification as the door leaves, may be included up to 1000 mm wide, with a minimum 30 mm thick softwood / hardwood mullion in accordance with Section 3 of the Data Sheet.

Overpanels / sidepanels shall be fixed using steel screws at a maximum of 400 mm centres and a maximum of 100 mm from each corner, through the centre of the panel to a depth of at least 30 mm

Intumescent seals as specified in Section 9 shall be fitted centrally to all for edges of the Overpanel / sidepanel or within the reveal of the frame.

5. Glazed Fanlights and Sidelights

Fanlights and Sidelights will comply with the following specification details:

Toplight / Sidelight Framing:	
Manufacturer:	Jeld-Wen UK
Reference:	FD30 Head
Material:	Softwood (solid or clear engineered tri-laminated and finger jointed material)
Density:	500 kg/m ³ minimum
Dimensions:	66 mm wide by 52 mm thick with a 48 mm wide by 20 mm deep rebate or 95 mm wide by 52 mm thick with a 48 mm wide by 20 mm deep rebate
Fixing Method:	Mortice and tenon joint, screwed and glued using 2No 5 mm Ø by 70 mm long hardened single thread woodscrews and HB Fuller Rakol Eco 3 Plus adhesive.
Sidelight Framing – T Section:	
Manufacturer:	Jeld-Wen UK
Reference:	FD30 T Head
Material:	Softwood (solid or clear engineered tri-laminated and finger jointed material)
Density:	500 kg/m ³ minimum
Dimensions:	48 mm wide by 70 mm thick with a 30 mm wide by 20 mm deep rebate or 77 mm wide by 70 mm thick with a 30 mm wide by 20 mm deep rebate.
Fixing Method:	T-Section mulled to door frame and fixed into position using 7No 4.2 mm Ø by 38 mm long woodscrews at 300 mm centres, 100 mm from the corners.
Coupled Sidelight / Toplight Fixings:	
Supplier:	Timber Mate Fastners
Description:	Pozi double CSK head wood screws
Reference:	Woodscrews
Dimensions:	4.2 mm Ø by 50 mm long
Position:	Screwed at 300 mm centres, 100 mm from the corners.
Sidelight Frame - Midrail:	
Manufacturer:	Jeld-Wen UK
Reference:	FD30 Direct Mulled Midrail Sidelight
Material:	Softwood (solid or clear engineered tri-laminated and finger jointed material)
Density:	500 kg/m ³ minimum
Dimensions:	66 mm wide by 150 mm thick with a 48 mm wide by 20 mm deep rebate.
Fixing Method:	Midrail butt jointed to mullion and frame, screwed and glued using 2No 4.2 mm Ø by 70 mm long CSK woodscrews (each side) and HB Fuller Rakol Eco 3 Plus adhesive.

Toplight / Sidelight – Glazing option 1 – Pyroguard T-EI30/16-1 VF - Insulated Glass			
Supplier:	CGI International		
Configuration:	Pyroguard T-EI30/16-1 VF		
Thickness:	19 mm		
Maximum pane dimensions:	Max. Height (mm)	Max. Width (mm)	Max. Area (m²)
Fanlight	515 (at 1977 wide)	2361 (at 432 high)	1.02
Full height sidelight	3033 (at 480 wide)	576 (at 2528 high)	1.46
Door height sidelight	2424 (at 990 wide)	1188 (at 2020 high)	2.40
Nominal edge clearance:	5 mm		
Setting Blocks:			
Supplier:	Ram Extrusions		
Reference:	Blue 60		
Description:	Glazing packers		
Dimensions:	4.8 mm by 100 mm by 15 mm		
Glazing System:			
Supplier:	Sealmaster		
Description:	Intumescent closed cell Tape – CF5645		
Reference:	CFT		
Dimensions:	15 mm by 3 mm		
Fixing Method:	Self-adhesive, applied to rebate and glazing bead		

Toplight / Sidelight – Glazing option 2 – Pyroguard EW30/6 VF RV - Non-insulated Glass			
Supplier:	CGI International		
Configuration:	Pyroguard EW30/6 VF RV		
Thickness:	13 mm		
Maximum pane dimensions:	Max. Height (mm)	Max. Width (mm)	Max. Area (m²)
Fanlight	506 (at 1962 wide)	2345 (at 422 high)	0.99
Full Height Sidelight	3019 (at 470 wide)	564 (at 2516 high)	1.42
Door Height Sidelight	2412 (at 980 wide)	1176 (at 2010 high)	2.36
Nominal edge clearance:	10 mm		

Setting Blocks:	
Supplier:	Ram Extrusions
Reference:	Blue 60
Description:	Glazing packers
Dimensions:	2No 5 mm by 100 mm by 10 mm (to provide 10 mm packer depth)
Glazing System:	
Supplier:	Sealmaster
Description:	Intumescent Foam Tape - CF5387
Reference:	GTR
Dimensions:	20 mm by 5 mm
Fixing Method:	Self-adhesive, applied to rebate and glazing bead
Glazing Beads:	
Glazing method:	Externally beaded
Supplier:	Jeld-Wen UK
Reference:	Splayed Flush Bead
Material:	Red Grandis Hardwood
Density:	570 kg/m ³ minimum
Dimensions:	20 mm by 24 mm
Fixing Method:	4 mm Ø by 40 mm long CS security screws, at maximum 150 mm centres, maximum 50 mm in from the corners.

Alternatively, any CERTIFIRE approved glazing systems may be used providing the specification and installation details given in the appropriate certification documents are adhered to.

6. Supporting Construction

The door assemblies are approved to be installed in brick, block, masonry, timber or steel stud supporting construction of overall minimum thickness 70 mm, providing at least 30 minutes fire resistance. Where stud partitions are used these should be suitably constructed to provide a secure fixing for the door assemblies as recommended by the partition manufacturer.

7. Installation

The opening may be lined with softwood, hardwood or plywood which shall be continuous and of minimum width, 70mm. Each door frame jamb to be fixed through to the wall at not less than three points with steel fixings at maximum 600 mm centres penetrating the wall to at least 50 mm. Architraves are optional with no restrictions on material, size or fixing.

In addition, the frame head of double-leaf doors shall be similarly fixed.

Door assemblies shall be installed as stated in BS 8214. Suitable CERTIFIRE approved lineal gap sealing systems may also be utilised to protect the frame/supporting construction gap, subject to the conditions contained within the relevant certificate.

Additionally, Fire and Acoustic Seals, Fire Door Foam (FD60) sealant may be used to the rear of frame installations for gaps up to 10 mm – to the full depth of the gap. This option may be utilised in conjunction with plastic packers.

The use of third party accredited installers provides a means of ensuring that installations have been conducted by knowledgeable contractors, to appropriate standards, thereby increasing the reliability of the anticipated performance in fire.

Unlipped door leaves may be trimmed to fit the frame by the following maximum amounts:

- Stiles (each): 4 mm
- Top: 3 mm
- Bottom: 6 mm

Doors lipped to the vertical edges with hardwood lippings, minimum 6 mm thick, with a minimum density of 650kg/m³ when used in conjunction with either Standard Option 1 or Standard Option 2 compliant intumescents may be trimmed to fit the frame by the following maximum amounts:

- Stiles (each): 4 mm
- Top: 3 mm
- Bottom: 6 mm

Note that the maximum door to frame and door to threshold gaps specified shall not be exceeded, nor shall the door edge fitted with the CERTIFIRE label be trimmed since removal of the label will invalidate the certification.

The labelled edge may be subjected to minor 'shooting-in', providing the label is not damaged or removed in the process, and the amount of material removed does not exceed that stated previously.

8. Glazed Apertures

All apertures to be factory prepared by Jeld-Wen UK Limited or a CERTIFIRE approved Licensed Door Processor. No site cutting of apertures permitted as this will invalidate the certification.

Additionally, the leaf / leaves may incorporate CERTIFIRE approved glass / glazing systems subject to the conditions contained within the relevant CERTIFIRE certificate (e.g., maximum size associated with glass or system, edge cover, intumescent aperture lining requirements, etc.) and the maximum pane dimensions given below (whichever is smaller).

This is subject to the apertures being lined with hardwood, minimum 42 mm wide by 6 mm thick, with a minimum density of 550kg/m³, excluding Iroko / Geronggang / Ash (unless stated otherwise in the glazing tables below). This arrangement would not require the further infilling of the tubes within the door leaf core.

When utilising alternative CERTIFIRE approved glazing systems that require a hardwood liner, the liner density requirements of the door and glazing system must be considered, and whichever is the greater of the two must be utilised.

Please note that where infilling is stated as being required in the glazing tables within this section of the Data Sheet, this infilling cannot be omitted.

Aperture dimensions: Doors may incorporate one or more vision panels to the maximum sizes identified in the table below:

Area: Maximum total glazed area of 0.85 m² per leaf

Height / Width: Maximum height and width as stated in the table below:

Maximum Permitted Aperture Dimensions		
Max. Height (mm)	Max. Width (mm)	Max. Area (m ²)
1000 (at 850 wide)	850 (at 1000 high)	0.85
1410 (at 248 wide)	248 (at 1410 high)	0.35

Margins: 100 mm from the perimeter edge, 100 mm between apertures

Lining to aperture*: 6 mm thick by 42 mm wide hardwood to be of minimum density 550 kg/m³, unless stated otherwise in the following glazing tables

Bead joints: Mitre joints to rectilinear glazing beads may include a gap of up to 1 mm where Intumescent type glazing systems are utilised. Mitre joints to glazing beads must be tight, where non-intumescent type glazing systems are utilised.

Double-leaf door assemblies with equal width leaves shall both be similarly glazed.

Hardwood or non-combustible setting blocks will be used where required to establish the correct edge cover.

The following specific glass / glazing systems are permitted in accordance with the specification details below

Non-Insulating glass: Rectilinear– Lorient Flexible figure 1 (/FF1) – MDF Beads

Glass Type	Intumescent System	Bead dimensions (mm)	Bead Density	Fixings	Max. Height (mm)	Max. Width (mm)	
7 mm Pyroshield 2, 6 mm Pyrostem or Pyroguard EW 30	Lorient Flexible Figure 1 (FF1)	25 mm high by min 23.5 mm wide (including a 7 mm by	MDF min. 720 kg/m ³ (Figure 3)	1.2 by 40 mm long pins at max 150 mm centres, max. 40 mm in from corners. Fixings angled at 45° to the vertical.	866 (at 162 wide) Max Area 0.14m ²	178 (at 787 high) Max Area 0.14m ²	
	Aperture lining	10 mm bolection)			Aperture references		
	6 mm min hardwood liner min 550 kg/m ³	Bead to include a 5° splay 12 mm +2/-1 mm edge cover			G01, G05, G06, G08, G10, G11 & G12		

Non-Insulating glass: Rectilinear– Sealmaster Intumescent Foam glazing tape – Meranti Beads

Glass Type	Intumescent System	Bead dimensions (mm)	Bead Density	Fixings	Max. Height (mm)	Max. Width (mm)	
7 mm Pyroshield 2	Sealmaster Intumescent Foam Glazing Tape	24.5 mm high by min 21.5 mm wide (including a 6 mm by 9.5 mm bolection)	Meranti Hardwood min. 480kg/m ³ (Figure 1)	1.6 by 40 mm long pins No.6 x 40 mm long screws at max 150 mm centres, max. 50 mm in from corners. Fixings angled at 45° to the vertical.	1410 (at 150 wide) Max Area 0.21m ²	510 (at 915 high) Max Area 0.47m ²	
	Aperture lining	Bead to include an 18° splay 12 mm +2/-1 mm edge cover			Aperture references		
	6 mm min hardwood liner min 550 kg/m ³				G01, G05, G06, G08, G10, G11 & G12		

Non-Insulating glass: Rectilinear– Sealmaster Intumescent Foam glazing tape – Meranti Beads

Glass Type	Intumescent System	Bead dimensions (mm)	Bead Density	Fixings	Max. Height (mm)	Max. Width (mm)	
6 mm Pyroclear	Sealmaster Intumescent Foam Glazing Tape	24.5 mm high by min 21.5 mm wide (including a 6 mm by 9.5 mm bolection)	Meranti Hardwood min. 480kg/m ³ (Figure 1)	1.6 by 40 mm long pins No.6 x 40 mm long screws at max 150 mm centres, max. 50 mm in from corners. Fixings angled at 45° to the vertical.	1410 (at 150 wide) Max Area 0.21m ²	510 (at 915 high) Max Area 0.47m ²	
	Aperture lining	Bead to include an 18° splay					
	6 mm min hardwood liner min 550 kg/m ³	12 mm +/-1 mm edge cover					
					Aperture references		
					G01, G05, G06, G10, G11 & G12		
7 mm Pyrodur Plus	Sealmaster Intumescent Foam Glazing Tape	24.5 mm high by min 21.5 mm wide (including a 6 mm by 9.5 mm bolection)	Meranti Hardwood min. 480kg/m ³ (Figure 1)	1.6 by 40 mm long pins No.6 x 40 mm long screws at max 150 mm centres, max. 50 mm in from corners. Fixings angled at 45° to the vertical.	225 (at 225 wide) Max Area 0.05m ²	225 (at 225 high) Max Area 0.05m ²	
	Aperture lining	Bead to include an 18° splay					
	6 mm min hardwood liner min 550 kg/m ³	12 mm +/-1 mm edge cover					
					Aperture references		
					G08		

Non-Insulating glass: Rectilinear– Sealmaster Intumescent Foam glazing tape – MDF Beads

Glass Type	Intumescent System	Bead dimensions (mm)	Bead Density	Fixings	Max. Height (mm)	Max. Width (mm)	
7 mm Pyroshield 2	Sealmaster Intumescent Foam Glazing Tape	25 mm high by min 23.5 mm wide (including a 7 mm by 10 mm bolection)	MDF min. 595 kg/m ³ (Figure 2)	1.6 by 40 mm long pins No.6 x 40 mm long screws at max 150 mm centres, max. 50 mm in from corners. Fixings angled at 45° to the vertical.	1410 (at 150 wide) Max Area 0.21m ²	510 (at 915 high) Max Area 0.47m ²	
	Aperture lining	Bead to include a 5° splay					
	6 mm min hardwood liner min 550 kg/m ³	12 mm +/-1 mm edge cover					
					Aperture references		
					G01, G05, G06, G08, G10, G11 & G12		
6 mm Pyroclear	Sealmaster Intumescent Foam Glazing Tape	25 mm high by min 23.5 mm wide (including a 7 mm by 10 mm bolection)	MDF min. 595 kg/m ³ (Figure 2)	1.6 by 40 mm long pins No.6 x 40 mm long screws at max 150 mm centres, max. 50 mm in from corners. Fixings angled at 45° to the vertical.	1410 (at 150 wide) Max Area 0.21m ²	510 (at 915 high) Max Area 0.47m ²	
	Aperture lining	Bead to include a 5° splay					
	6 mm min hardwood liner min 550 kg/m ³	12 mm +/-1 mm edge cover					
					Aperture references		
					G01, G05, G06, G10, G11 & G12		
7 mm Pyrodur Plus	Sealmaster Intumescent Foam Glazing Tape	25 mm high by min 23.5 mm wide (including a 7 mm by 10 mm bolection)	MDF min. 595 kg/m ³ (Figure 2)	1.6 by 40 mm long pins No.6 x 40 mm long screws at max 150 mm centres, max. 50 mm in from corners. Fixings angled at 45° to the vertical.	225 (at 225 wide) Max Area 0.05m ²	225 (at 225 high) Max Area 0.05m ²	
	Aperture lining	Bead to include a 5° splay					
	6 mm min hardwood liner min 550 kg/m ³	12 mm +/-1 mm edge cover					
					Aperture references		
					G08		

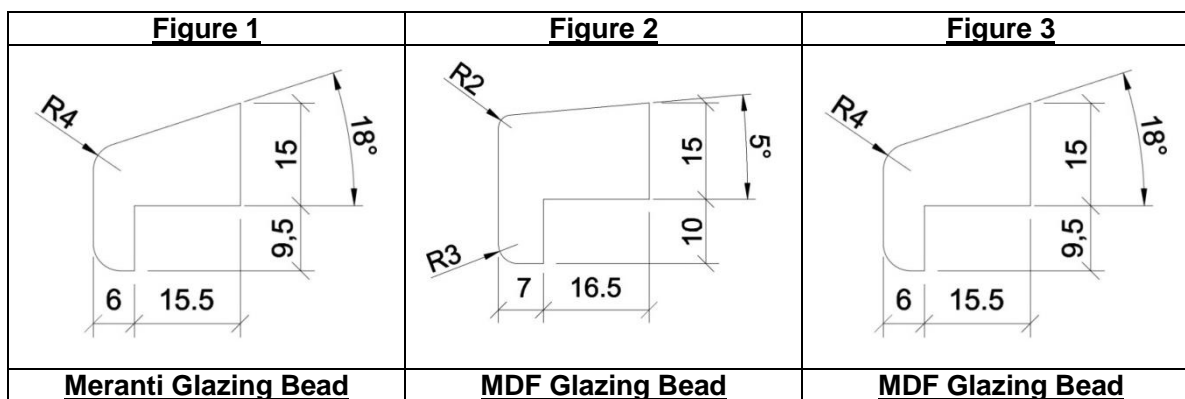

Non-insulating glasses: 6 mm thick Pyroshield 2, Pyrostem, Georgian Wired polished plate, Pyroguard C/W or Pyran S.

Glass	Intumescent System	Bead dimensions (mm)	Bead Density	Fixings	Max. Height (mm)	Max. Width (mm)	Max. Area (m ²)
Pyroshield 2 or Pyrostem	Therm-A-Strip at 10 mm by 2 mm Aperture to be lined with 6 mm thick hardwood with a min density of 550 kg/m ³	Min 22 mm high by 25 mm wide (including a 5mm Bolection). Beads can be square topped or include up to a 10° splay. (15 mm edge cover)	MDF minimum 720 kg/m ³	Min 38 mm long steel pins or screws at max 150 mm centres, skew fixed at approx. 20°. Min 2No fixings per bead length.	910 (at 660 wide)	735 (at 735 high)	0.60
Pyroshield 2 or Pyroguard C/W	Therm-A-Strip at 10 mm by 2 mm Aperture to be lined with 6 mm thick hardwood with a min density of 550 kg/m ³	Min 23 mm high by 25 mm wide splayed (including a 10 mm high by 7 mm wide Bolection).	Hardwood minimum 550 kg/m ³	Min 40 mm long steel pins or screws at max 200 mm centres, skew fixed at approx. 35° to vertical. Max 40 mm in from each corner	1000 (at 850 wide)	850 (at 1000 high)	0.85
					1150 (at 150 wide)	150 (at 1150 high)	0.173
Pyroshield 2, Pyroguard C/W or Pyran S	Therm-A-Strip at 10 mm by 2 mm Aperture to be lined with 6 mm thick hardwood with a min density of 550 kg/m ³	Min 22 mm high by 25 mm wide or 15 mm high by 25 mm wide (including a 5mm Bolection). Beads can be square topped or include up to a 10° splay. (15 mm edge cover)	MDF minimum 720 kg/m ³	Min 38 mm long steel pins or screws at max 150 mm centres, skew fixed at approx. 20° to vertical Min 3No fixings per bead length.	910 (at 659 wide)	726 (at 826 high)	0.60
					1410 (at 248 wide)	250 (at 1400 high)	0.35
Pyroshield 2	Pyrostrip 300 at 15 mm by 2 mm Aperture to be lined with Pyrostrip 300L at 44 mm by 2 mm and entire extruded tube at bottom of vision panel to be filled with Intuplus – as detailed in Figure 4	Min 19 mm high by 21 mm wide splayed (including a 4mm high by 6 mm wide Bolection). Glass to be set on a hardwood setting block 6 mm wide by 3 mm thick	Hardwood minimum 640 kg/m ³	Min 50 mm long steel screws at max 150 mm centres, skew fixed at approx. 35° to vertical Max 40 mm in from each corner	770 (at 636 wide)	642 (at 763 high)	0.49

Non-insulating glasses: 6 mm thick Pyroshield 2, Pyrostem, Georgian Wired polished plate, Pyroguard C/W or Pyran S.

Glass	Intumescent System	Bead dimensions (mm)	Bead Density	Fixings	Max. Height (mm)	Max. Width (mm)	Max. Area (m ²)
Pyroshield 2	Pyroglaze at 10 mm by 3 mm Aperture to be lined with Pyrostrip 300L at 44 mm by 2 mm and entire extruded tube at bottom of vision panel to be filled with Intuplus – as detailed in Figure 4	Min 19 mm high by 21 mm wide splayed (including a 4mm high by 6 mm wide Bolection). Glass to be set on a hardwood setting block 6 mm wide by 3 mm thick	Hardwood minimum 640 kg/m ³	Min 50 mm long steel screws at max 150 mm centres, skew fixed at approx. 35°. Max 40 mm in from each corner	770 (at 636 wide)	642 (at 763 high)	0.49
Pyroshield 2	Intuplus at 15 mm by 2 mm Aperture to be lined with Therm-A-Line at 44 mm by 2 mm and entire extruded tube at bottom of vision panel to be filled with plaster – as detailed in Figure 4	Min 19 mm high by 21 mm wide splayed (including a 4mm high by 6 mm wide Bolection). Glass to be set on a hardwood setting block 6 mm wide by 3 mm thick	Hardwood minimum 640 kg/m ³	Min 50 mm long steel screws at max 150 mm centres, skew fixed at approx. 35°. Max 40 mm in from each corner	960 (at 310 wide)	310 (at 960 high)	0.30

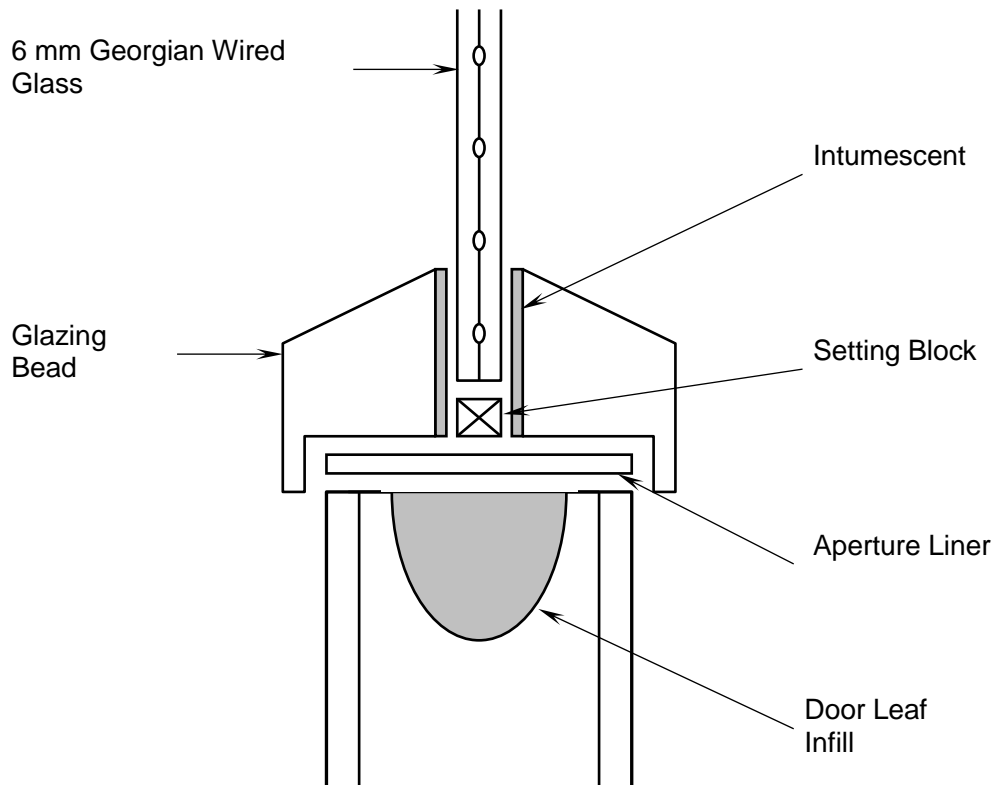

Figure 4. – Tube infilling detail

9. Intumescent Seals

CERTIFIRE certificated intumescent seals are required to be fitted to these doors as below.

Door assemblies to BS476: Part 22 – classified as FD30

Standard Option 1 - Lorient Polyproducts LP1504 (Type 617) - Leaf sizes as stated in Table 1

Door assembly Configuration	Position	Required Intumescent Protection
Single-acting, Single-leaf	Head	1 No. 15 mm wide by 4 mm thick seal fitted at the centre of the leaf edge or within the reveal to the frame or transom rail
	Vertical edges	1 No. 15 mm wide by 4 mm thick seal fitted at the centre of the leaf edge or within the reveal to the frame or transom rail
Single-Acting, Double-Leaf	Head	1 No. 20 mm wide by 4 mm thick seal fitted centrally within the reveal to the frame.
	Hanging edges	1 No. 15 mm wide by 4 mm thick seal fitted centrally within the reveal to the frame or transom rail
	Meeting edges	1 No. 15 mm wide by 4 mm thick seal fitted in the edge of both leaves, offset from centre such that the seals are not opposing.

Standard Option 2 - Pyroplex (CF355) - Leaf sizes as stated in Table 1

Door assembly Configuration	Position	Required Intumescent Protection
Single-acting, Single-leaf	Head	1 No. 15 mm wide by 4 mm thick seal fitted at the centre of the leaf edge or within the reveal to the frame or transom rail
	Vertical edges	1 No. 15 mm wide by 4 mm thick seal fitted at the centre of the leaf edge or within the reveal to the frame or transom rail
Single-Acting, Double-Leaf	Head	1 No. 15 mm wide by 4 mm thick seal fitted at the centre of the leaf edge or within the reveal to the frame or transom rail
	Hanging edges	1 No. 15 mm wide by 4 mm thick seal fitted at the centre of the leaf edge or within the reveal to the frame or transom rail
	Meeting edges	2 No. 10 mm wide by 4 mm thick seals in the edge of the primary leaf, positioned 8 mm and 20 mm from the opening face of the door leaf.

Reduced Intumescent Option - Lorient Polyproducts Type 617 – Leaf sizes as stated in Table 2

Door assembly Configuration	Position	Required Intumescent Protection
Single-acting, Single-leaf	Head	1 No. 10 mm wide by 4 mm thick seal fitted at the centre of the leaf edge or within the reveal to the frame
	Vertical edges	1 No. 10 mm wide by 4 mm thick seal fitted at the centre of the leaf edge or within the reveal to the frame
Single-Acting, Double-Leaf	Frame Head	1 No. 10 mm wide by 4 mm thick seal fitted 15 mm from the opening face of the frame within the reveal to the frame.
	Top edge of door leaf	1 No. 10 mm wide by 4 mm thick seal fitted 9 mm from the opening face of the door leaf
	Hanging edges	1 No. 10 mm wide by 4 mm thick seal fitted 15 mm from the opening face of the frame within the reveal to the frame.
	Meeting edges	1 No. 10 mm wide by 4 mm thick seal in the edge of both leaves. The primary meeting edge seal is positioned 9 mm from the closing face of the door leaf & the secondary leaf meeting edge seal is positioned 9 mm from the opening face of the door leaf.

Seals may be interrupted at hinge and latch positions.

Latched or unlatched, single acting, single-leaves with maximum leaf dimensions 2040 mm high by 926 mm wide and of a minimum thickness of 43 mm may utilise alternative Intumescents in-line with the relevant CERTIFIRE approval for the proposed intumescent seal. All seals to be CERTIFIRE approved (to Technical Schedule 35).

All other door assembly configurations should include the specific intumescent size type and location as specified within the data sheet.

Smoke seals may be included subject to the conditions contained within the relevant CERTIFIRE certificate for the smoke seal, including but not limited to the Lorient Polyproducts IS1212, which, where required shall be uninterrupted and fixed around the head and vertical edges of the frame.

See Section 3 for intumescent requirements when using Softwood Tri-laminated, finger jointed frames.

10. Hinges

Hinges shall be CE marked against EN 1935 for use on 30 minute timber fire door assemblies.

Number:	Minimum 3 No.	
Type:	Steel lift off or butt hinges.	
Positions:*	Top hinge:	Max 250 mm from the top of the door
	Bottom hinge:	Max 250 mm from the bottom of the door
	Third hinge:	<ul style="list-style-type: none"> • Positioned centrally between the top & bottom hinge. • Positioned max 300 mm below the top hinge.
Dimensions:	Height:	100 mm +/-20%
	Blade width:	35 mm +/- 3 mm
	Thickness:	3 mm (+/- 0.5 mm)
	Knuckle dia.:	13 mm (+/- 1 mm)
Fixings:	Minimum 4No. steel screws, 3 or 4 mm diameter by 30 mm long.	
Intumescent Protection**	None required.	
	Option to include 1 mm thick Interdens intumescent sheet material under hinge blades permitted.	

Or

Number:	Minimum 3 No.	
Type:	Steel lift off or butt hinges.	
Positions:*	Top hinge:	Max 300 mm from the top of the door
	Bottom hinge:	Max 300 mm from the bottom of the door
	Third hinge:	<ul style="list-style-type: none"> • Positioned centrally between the top & bottom hinge. • Positioned max 300 mm below the top hinge.
Dimensions:	Height:	100 mm (+/-20%)
	Blade width:	35 mm (+1 mm / - 3 mm)
	Thickness:	3 mm (+/- 0.5 mm)
	Knuckle dia.:	13 mm (+/- 1 mm)
Fixings:	Minimum 4No. steel screws, 3 or 4 mm diameter by 30 mm long.	
Intumescent Protection**	None required.	
	Option to include 1 mm thick Interdens intumescent sheet material under hinge blades permitted.	

Or

Number:	Minimum 3 No.	
Type:	Steel butt hinges.	
Positions:*	Top hinge:	Max 300 mm from the top of the door
	Bottom hinge:	Max 300 mm from the bottom of the door
	Third hinge:	<ul style="list-style-type: none"> • Positioned centrally between the top & bottom hinge. • Positioned max 300 mm below the top hinge.
Dimensions:	Height:	100 mm +/-20%
	Blade width:	25 mm + 3 / - 0 mm
	Thickness:	2 mm (+ 0.5 / - 0 mm)
	Knuckle dia.:	10 mm (+ 1 / - 0 mm)
Fixings:	Frame Fixings	Minimum 4No. steel screws, 3 or 4 mm diameter by 19 mm long.
	Door Fixings:	Minimum 4No. steel screws, 3 or 4 mm diameter by 32 mm long.
Intumescent Protection**	None required.	
	Option to include 1 mm thick Interdens intumescent sheet material under hinge blades permitted.	

* The datum in all cases is the centreline of the hinge.

** This specification overrides any requirement for additional intumescent identified in the hinge manufacturer's certification providing the hinge specification falls within the parameters identified above, specifically maximum dimensions and material.

Any other CERTIFIRE approved hinge may be fitted, providing the hinge dimension are no greater than 10% in blade width and 25% in blade height from that approved above.

Where the Certifire approved hinge exceeds the specification given above, the minimum requirement for intumescent protection to the hinges, by-passing perimeter intumescent, and the material density and thickness for the door and frame elements given in the hinge manufacture's CERTIFIRE certificate shall apply.

Any other CERTIFIRE approved hinges may be used, subject to the conditions contained within the relevant certificate.

11. Locks and Latches

Locks / latches are not necessary, but where fitted locks / latches shall be CE Marked for use on 30 minute timber fire doors.

Mortice type, automatic (sprung) latch bolt.

Unlipped Door Leaves Only	
Max. case dimension:	120 mm high by 90 mm deep by 22 mm wide
Max. forend dimension:	165 mm high by 26 mm wide
Max. keep dimension:	165 mm high by 25 mm wide (excluding latch plate)
Latchbolt material:	Steel or material with a melting point greater than 850°C
Position:	Max. 1200 mm from bottom of door to centreline of lockcase
Intumescent: protection*	None Required

Or

Lipped Door Leaves Only	
Max. case dimension:	102 mm high by 65 mm deep by 14 mm wide
Max. forend dimension:	150 mm high by 22 mm wide
Max. keep dimension:	150 mm high by 22 mm wide (excluding latch plate)
Latchbolt material:	Steel or material with a melting point greater than 850°C
Position:	Max. 1000 mm from bottom of door to centreline of spindle
Intumescent: protection*	None Required

Or

Lipped or Unlipped Door leaves	
Max. case dimension:	165 mm high by 90 mm deep by 22 mm wide
Max. forend dimension:	235 mm high by 24 mm wide
Max. keep dimension:	180 mm high by 39 mm wide (including a 135 mm by 15 mm lip)
Latchbolt material:	Steel or material with a melting point greater than or equal to 850°C
Position:	Max. 1200 mm from bottom of door to centreline of spindle
Intumescent: protection*	Latch case, forend and keep to be bedded onto 1 mm thick Interdens intumescent sheet material.

* This specification overrides any requirement for additional intumescent identified in the lock manufacturer's certification providing the lock/latch specification falls within the parameters identified above, specifically maximum dimensions and material.

Any other CERTIFIRE approved lock/latch may be fitted, providing no lock/strikeplate dimension is more than 25% of that approved above and subject to the conditions contained within the relevant certificate.

Where the Certifire approved lock/latch exceeds the specification given above, the minimum requirement for intumescent protection to the locks, latches and strikeplates, by-passing perimeter intumescent, and the material density and thickness for the door and frame elements given in the lock/latch manufacture's CERTIFIRE certificate shall apply.

Recessing for locks should result in a tight fit, allowing for any intumescent protection where required.

No restriction on type and material of mechanical lever handles and knobs.

Salto Locks

Salto lock cases complete with card readers in accordance with CF5596 may be fitted in accordance with the following specification requirements:

- Max case: 165 mm by 100 mm by 15 mm
- Max strike: 170 mm long by 24 mm wide (excluding lip)
- Max forend: 235 mm by 24 mm
- Min door thickness of 44 mm
- Doors to be lipped to vertical edges with hardwood with a minimum density of 650kg/m³.
- Recess for lock and card reader to be fully lined with 1 mm thick Interdens intumescent sheet material
- Forend and strike to be bedded on 1 mm thick Interdens intumescent sheet material
- Locks are to be fitted no higher than 1100mm from the spindle to the finished floor level.

12. Self-Closing Devices

All doors are required to be fitted with a CERTIFIRE certificated self-closing device. The exceptions are doors kept locked shut such as service access doors. Note: closers with mechanical hold-open mechanisms are not permitted to be used. Building Regulations may identify locations within domestic locations where self-closing devices are not mandatory.

The closers shall have a power rating appropriate to the leaf sizes, subject to the closer having the ability to close the door from any angle and against any latch and/ or seals fitted. The closer shall have the ability to provide a minimum size 3 closing force. Where doors are unlatched a minimum size 3 shall be maintained.

Closers shall be CE Marked against EN 1154 and categorised as grade 1 – suitable for use on fire / smoke door assemblies.

12a Surface mounted overhead closers

Any CERTIFIRE approved surface mounted overhead closer may be fitted, subject to the conditions contained within the relevant certificate.

12b Transom Mounted and Concealed Closers

Not permitted

12c Floor Springs

Not permitted

12d Jamb mounted Door Springs

Jamb mounted door springs referenced 'Henderson Model 140', 'Perko R1/R2' and 'Perkomatic R85' may be used in accordance with the guidance stated within Approved Document B as follows:

- May be used on doors within a dwellinghouse, excluding doors between a dwellinghouse and an integral garage.
- May be used on doors within flats, excluding flat entrance doors.
- May be used on doors to cupboards and service ducts which are normally kept locked.
- All other fire doors should be fitted with a self-closing device as previously stated.
- Furthermore, the use of jamb mounted door springs is limited to latched, single-acting, single-leaf door assemblies for internal use only.

The use of Henderson Model 140, Perko R1/R2 and Perkomatic R85 jamb mounted door springs is permitted on the basis that, when the door is latched shut, it will not detract from the fire performance of the door assembly in the event of a fire. The door springs are NOT CERTIFIRE approved, and no claims are made or should be implied or inferred on the ability of the device to close and latch the door or in respect of its mechanical performance or durability.

Jamb mounted door springs are not suitable for use with the reduced intumescent specification.

13. Ancillary items

Please note that hardware items other than those discussed within this certificate of approval are not permitted.

13a Protection plates and signage

Surface mounted plastic, steel, aluminium or brass plates are acceptable on the following basis:

- < 2mm thick
- Do not occupy more than 20% of the door leaf in total or exceed 500mm in height for kickplates and 300mm for mid-plates, whichever is the smaller.
- Do not wrap around the vertical edges, and on the closing face do not extend beneath the door stops (generally 40-50mm narrower than door width)
- Plates/signage can be bonded with a thermally softening adhesive. Additionally, screws may be used.

13b Flushbolts

Where flushbolts are fitted the primary leaf must be latched and the flushbolts must be engaged.

Max. dimension	205 mm high by 37 mm deep by 19 mm wide
Material:	Steel
Position:	Top and bottom on door edge or face (positioned a minimum of 50 mm from the leading edge of the door to the centre of the bolt).
Intumescent protection*	1 mm Interdens sheet to base and sides of bolt body and beneath the keep.

Barrel bolts which are wholly surface mounted and do not encroach into the door/frame gap may be fitted providing these items are screw fixed only, and not bolted through the full thickness of the door

13c Pull Handles

Screw-fixed, bolt-fixed from the back and back-to-back fixed pull handles of steel, brass, aluminium and nylon coated, are permitted providing any through-bolt fixing is of steel.

13d. Air transfer grilles

No site cutting of apertures permitted as this will invalidate the certification.

Where apertures are pre-cut by Jeld-Wen UK Limited, or a CERTIFIRE approved Licensed Door Processor, Intumescent Air Transfer Grilles may be fitted on site by NON-CERTIFIRE approved staff, however, the Intumescent Air Transfer Grilles shall be CERTIFIRE approved for use in FD30 timber based doors.

The air transfer grilles must be fitted into apertures prepared in line with the relevant CERTIFIRE certificate for the air transfer grille. Care must be taken to ensure all fitting instructions are followed, including any constraints imposed by the CERTIFIRE certificate with regards to position of the air transfer grille within the door assembly.

Apertures provided within door leaves for the purpose of fitment with Intumescent Air Transfer Grilles shall be lined with hardwood with a minimum thickness of 6 mm and a minimum density of 550 kg/m³.

13e. Letter Plates

Where letter plates are fitted, the aperture for a letter plate may be formed on site by NON-CERTIFIRE approved staff, however, the letter plates shall be CERTIFIRE approved for use in FD30 timber based tubular cored doors specifically. Where the letter plate certificate states letter plates shall be fitted within solid cellulosic cored doors only, they are not suitable to be fitted within CF192 doors.

Letter plates approved specifically for use within timber based tubular cored doors, must be fitted into apertures prepared in line with the relevant CERTIFIRE certificate for the letter plate. Care must be taken to ensure all fitting instructions are followed, including any constraints imposed by the CERTIFIRE certificate with regards to position of the letter plate within the door assembly.

13f. Door Viewers

Door viewers may be fitted into the leaf providing the viewer comprises a metal sleeve and an optical glass lens and is not positioned higher than 1500 mm from the threshold to the centre line of the viewer barrel.

The viewer should have an external diameter of not greater than 15 mm be tightly fitted within the leaf.

The aperture provided for the installation of the viewer should be fully lined with 1mm thick Interdens intumescent sheet material, ensuring that the viewer is a tight fit.

One or more door viewers may be fitted providing a minimum of 100 mm centre-to-centre is retained between viewers.

Additionally, door viewers referenced UK Fixings 22528 may be utilised.

13g. Coat Hooks and Other Surface Mounted Hardware

Ancillary items which are wholly surface mounted may be fitted providing:

- These items are screw fixed or bonded only
- Are not bolted through the full thickness of the door
- Are not directly above, or closer than 100 mm to any non-insulated glazing

13h. Dropseals

CERTIFIRE approved dropseals may be fitted to the bottom edge of CF192 door leaves, including, but not limited to the Lorient Polyproducts LAS8001si.

Fire and Acoustic Seals, FAS45 dropseals with overall dimensions 21 mm high by 11 mm wide are also permitted.

Where dropseals are fitted, the recess for a dropseal may be formed on site by NON-CERTIFIRE approved staff. Care must be taken to ensure all fitting instructions are followed, including any constraints imposed by the CERTIFIRE certificate.

Note: Threshold gaps as stated in Section 3 are to be maintained

13i. Electric Strikes / Electromechanical locks

Not permitted

14. Further Information

Further information regarding the details contained in this data sheet may be obtained from JELD-WEN UK Limited (Tel. 0114 229 3250).

Further information regarding the CERTIFIRE certification and other approved products can be obtained from Warringtonfire Testing and Certification (Tel: +44 (0) 1925 646777).